

Guide to contents - applicable to

5MC software V67

1 Mechanical Outlines

Referring to the appropriate size of XFE, mount the XFE ensuring that correct clearances are maintained for adequate ventilation and operation of the XFE.

2 Wiring Diagrams

Referring to the appropriate **Wiring Diagram**, install the XFE electrical connections ensuring that the correct control supply voltage is used and is within its specified operating limits as described on the product specification

ACCESS

Caution Always replace the cover panel on the unit after gaining access to the electrical connections.

The unit requires two AC supplies:

A 3 phase balanced Mains Supply to provide the source of power for the controlled motor.

A single phase supply: 115V/230V, 50Hz/60Hz, for the internal control circuitry.

XFE 300 series need a separate 115V or 230V supply to power the fans.

Voltage must be specified prior to supply of the XFE.

IMPORTANT Ensure that the voltage selector switch position corresponds to the control supply before you apply the control supply voltage.

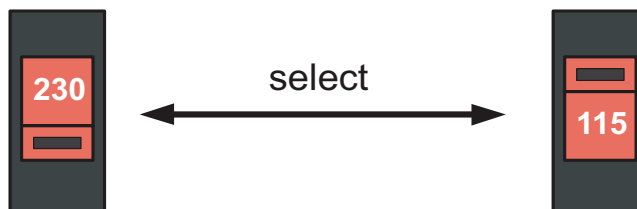

ISOLATION

Caution: The XFE uses semiconductor devices in the main circuit and is not designed to provide isolation. For this reason isolation means must be installed in the supply circuit in accordance with the appropriate wiring and safety regulations.

The Mains Supply and the Control Supply each require protection. Although all units have electronic overload protection, the installer should always place fuse protection **between** the unit and the Mains Supply, **not between** the unit and the motor. Semiconductor fuses can be supplied for short circuit protection of the semiconductors.

3 Keypad operation and basic set-up

Refer to this, for familiarisation with the keypad controls of the XFE. Use the illustration of the Basic Menu structure to find XFE menu items on the display.

4 Set-up examples

Set-up basic XFE operating parameters, if necessary, by following one or all of the examples described here.

5 Product information

Refer to product information for details of Design Standards and Approvals, operating and storage limits and other installation instructions.

Further Information

Further information about the XFE soft start motor controller, detailed manuals and application notes are available on the Fairford website or from Fairford direct (see back page for contact details).

1 Mechanical Outlines

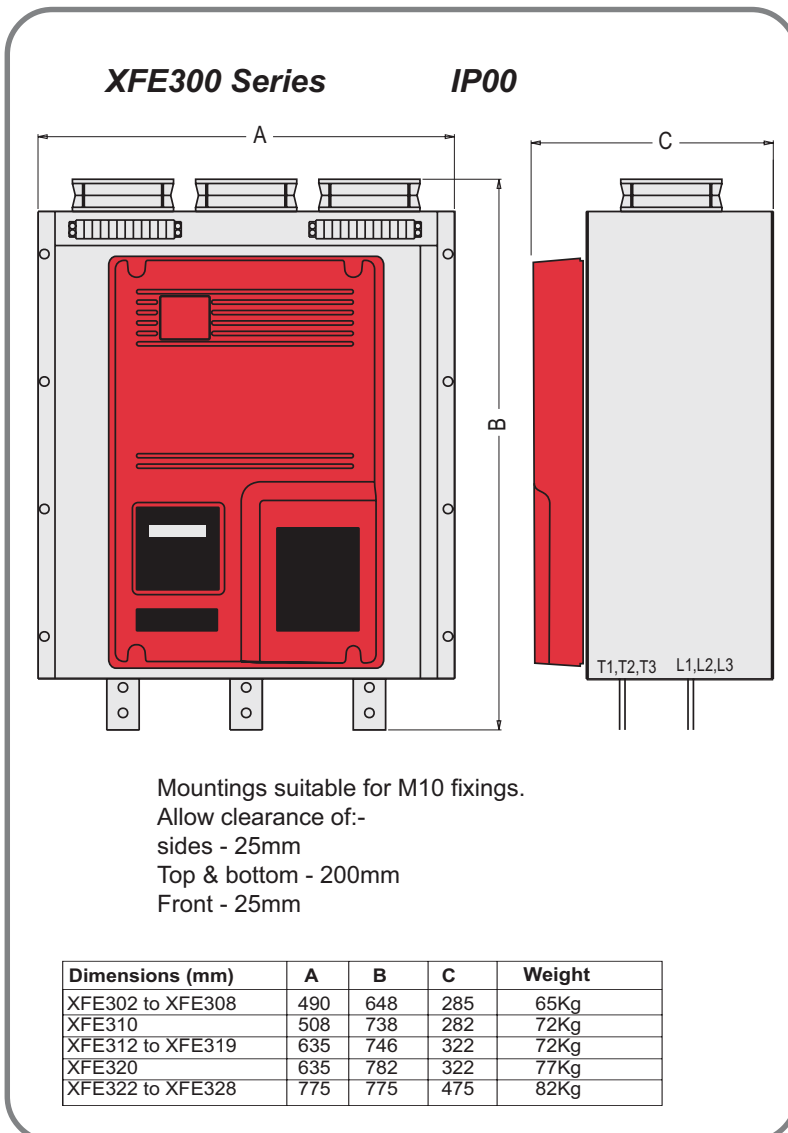
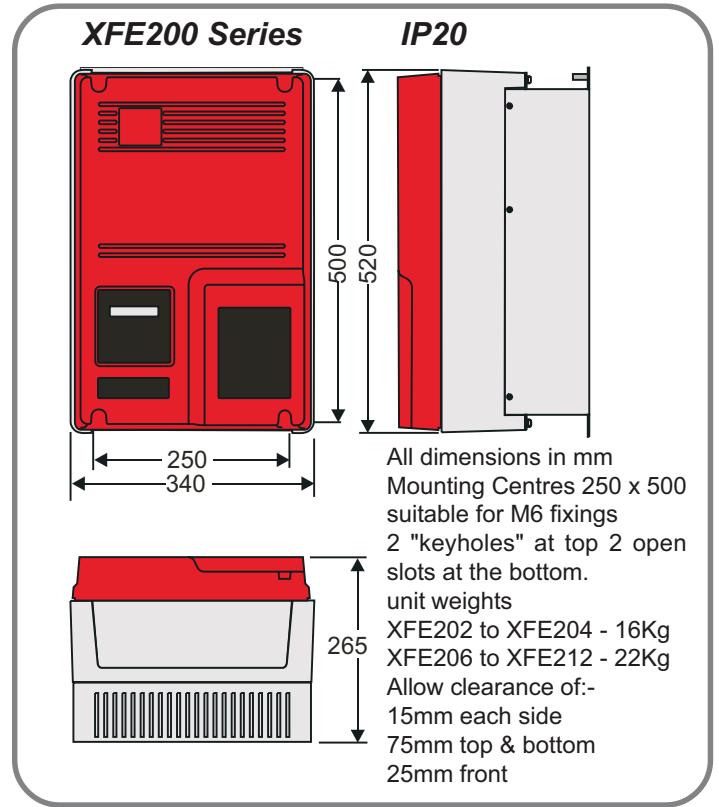
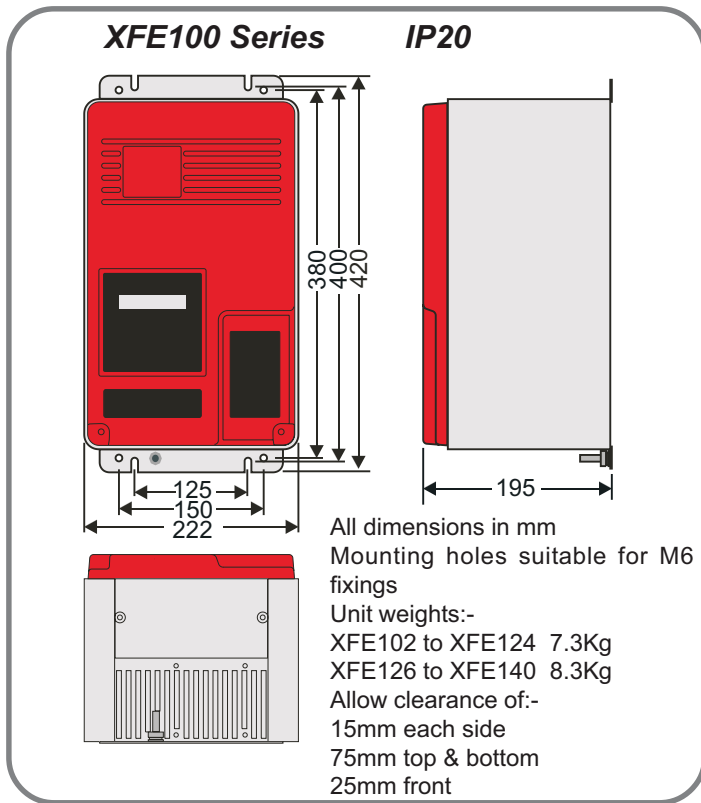

Enclosure Ventilation

When fitting the XFE into a cabinet, ventilation must be provided if the heat output of the unit is greater than the cabinet will dissipate. Use the following formula to determine the fan requirement. An allowance has been incorporated into the formula so that the figure for "Q" is the air delivery quoted in the fan suppliers data.

An approximation of the heat produced (Watts) by the XFE, when in circuit, can be made by multiplying the line current by three.

When the XFE is bypassed the heat output can be approximated with the formula:-

Watts (soft starter) = Start current x start time in seconds x number of starts per Hour / 800

Exact figures for unit full load current are in the XFE manual.

Q = volume of air (cubic metres per hour - m³/h)

Wt = heat produced by the unit and all other heat sources within the enclosure (Watts)

t_{max} = maximum permissible temperature within the enclosure (40°C for a fully rated XFE)

t_{amb} = temperature of the air entering the enclosure (°C)

If you prefer to work in CFM, substitute °F for °C. Q is now in CFM.

$$Q = \frac{4 \times Wt}{(t_{max} - t_{amb})}$$

2 Wiring Diagrams

Fig 2.1 Control circuit wiring

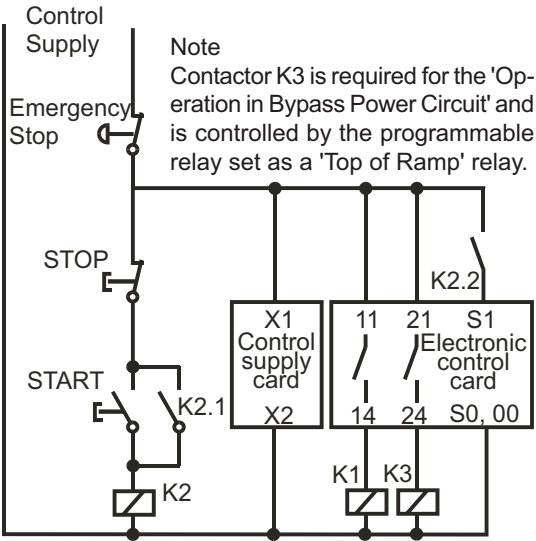

Note: Extra X1-X2 on 300 Series for fan supply

The **Electronic control card** is located underneath the cover in the all units.

Connections shown in the control circuit wiring diagram are made to the electronic control card terminals as shown in fig.2.2 below.

Fig 2.2

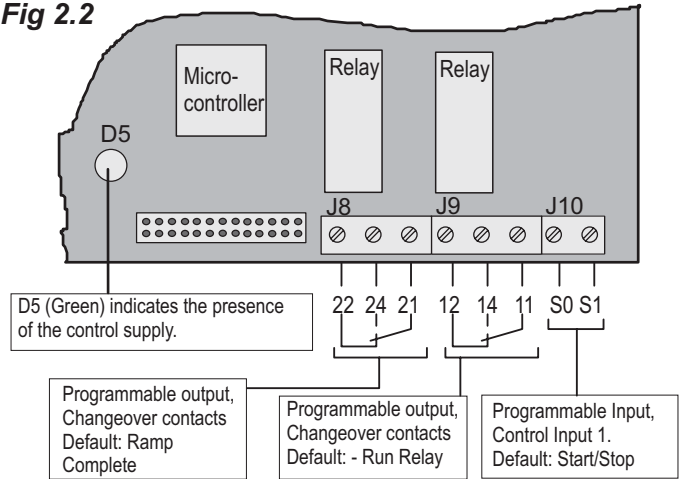

Use the control circuit with one of these power circuits

Fig 2.3 Power circuit for In-Line connection of motors (see note 3).

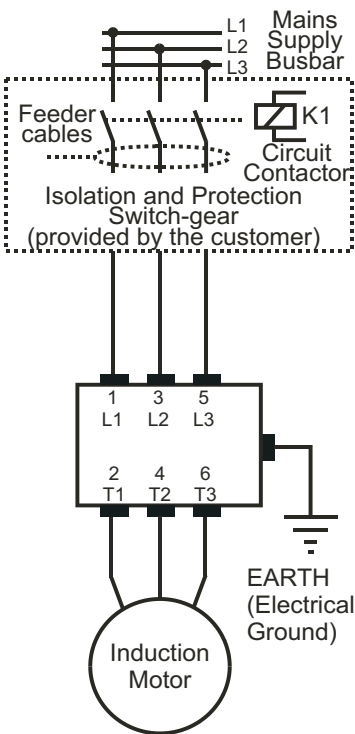

Fig 2.4 Power circuit for In-Delta connection of motors (see note 4).

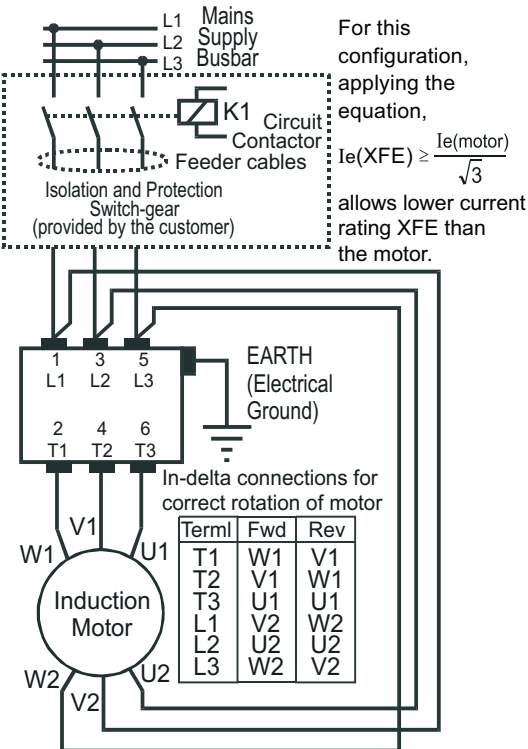
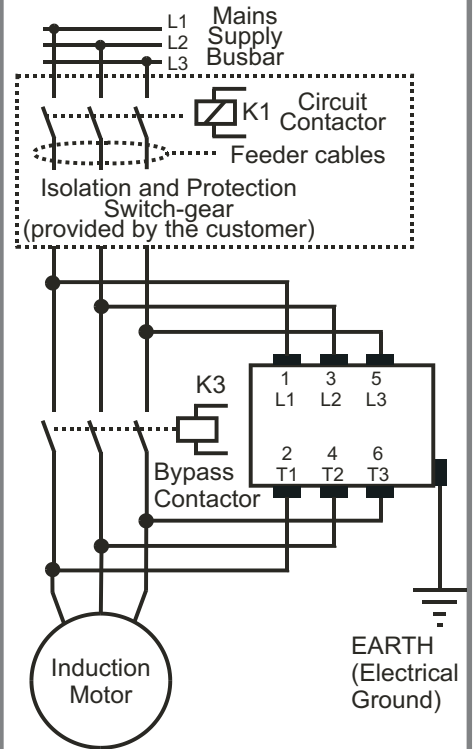

Fig 2.5 Power circuit for bypass operation (see note 5).



Important

Note 1: Correction capacitors:

Power factor correction capacitors must **NOT** be positioned on the output of the power circuit.

Note 2: Fuse Selection:

Where semiconductor type fuses are required, they should be selected from the table in Section 5.

Note 3: The in-line configuration shown in Fig 2.3 requires that the firing mode be set to '0'.

Note 4: The **In-Delta configuration** as in Fig 2.4 requires that the Firing Mode be set to '1'.

An in-line contactor controlled by the XFE **MUST** be used with the In-Delta firing mode.

Note 5: The **bypass configuration** as in Fig 2.5 is automatically detected as "Auto bypass" is set as default.

3 Keypad operation and basic set-up

ALWAYS ENSURE THAT THE KEYPAD CABLE IS PLUGGED IN BEFORE APPLYING POWER TO THE UNIT

When wired as Fig 2.1, page 3, the XFE display will indicate start up messages followed by 'Stopped and ready'. At this point:

- the XFE will start the motor when the keypad 'START/STOP' key is pressed but not when the START switch as shown in Fig.2.1 is closed.
- the XFE parameters are set to factory default which may not be ideal for the required application.

The examples in section 4 show how to set up some of the essential XFE operating parameters using the keypad. Once these are understood, other XFE settings, as indicated in the programming Menu Structure, can be set in a similar manner (The corresponding default settings are shown in brackets). For the full menu structure see page 6 .

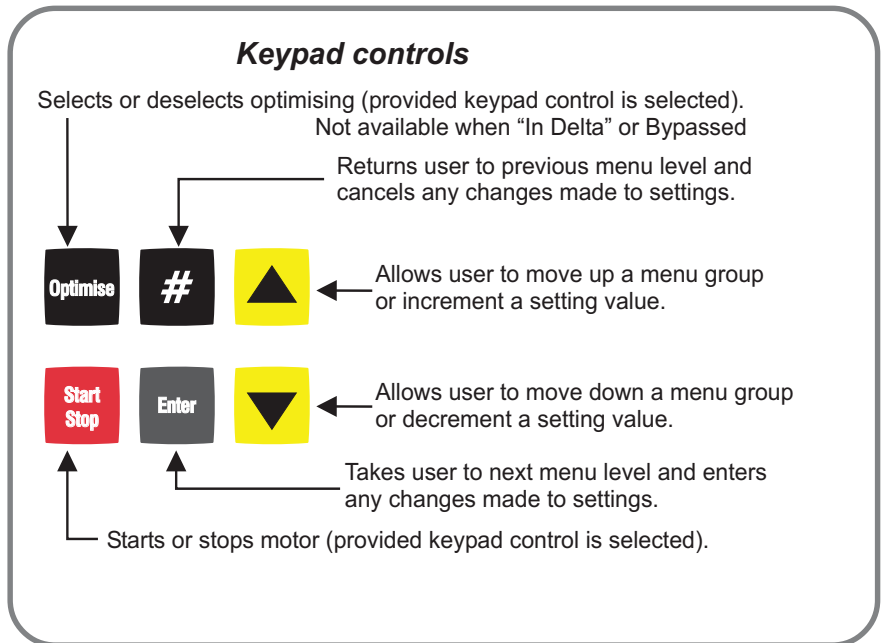

Keypad start-up message

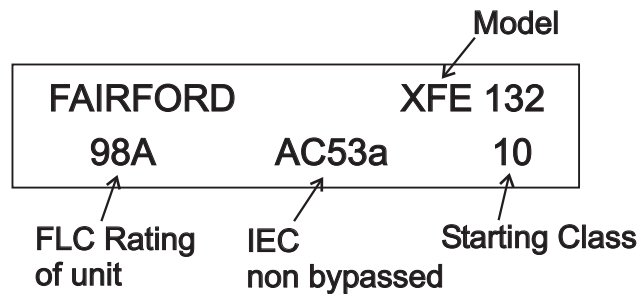

XFE Soft Starts are either supplied pre-set to a Start Class or ready to set. An application selector chart is available from FE to aid in the selection of the correct XFE. If the unit is supplied ready to set then it will force the selection of a starting Class when first powered up.

It is always possible to change the starting Class through menu item >Advanced > current > P106 start class

When the motor is running the XFE can display **current** (default) or **Estimated Power**. Pressing the # key at the top of the menu structure allows the user to toggle between these 2 options.

Cooling

The XFE is designed so that the rated start current/time is close to the maximum allowed. If the start duty is exceeded the unit will trip. All XFE Soft Starts have a forced off cooling time between starts.

In line with the stated IEC starting duties, all XFE 100 series have an enforced off period of 2 minutes, likewise all XFE 200 and XFE 300 series have an enforced off period of 7 minutes set as standard. During this period the display indicates "**Stopped.Cooling**" and the XFE will not respond to a start signal.

AC53a ratings are for Optimising or use without a bypass contactor.

AC53b rating is only for use with a bypass contactor and will trip if one is not used

Starter Enable/Disable

An additional safety feature has been added so that following certain actions the XFE will be disabled. It is strongly recommended that before any changes to parameter values are made, that the XFE is **disabled** via the **Basic Menu**. Once disabled, the XFE remains unable to drive the load, until it has been **enabled** via the **Basic Menu**, or the control supply is removed and reapplied, or the ▼ key is pressed when prompted.

XFE Soft Starters may be set up to 1 of 8 overload start duty settings. The applicable motor current and duty ratings for all the range are shown in the table on the back page of the main manual. The following tables give the full operating data for 2 sample Soft Starts.

XFE138	Start Class	Maximum Motor FLC	IEC Utilisation Category	Motor Overload Class	Maximum unit current x Motor FLC	Start Time	Starts per Hr	Duty Ratio (AC53a) Bypassed + Off Time (AC53b)
1	10B	154A	AC53a	10A	3.5	12	5	75%
2	10	166A	AC53a	10	3	23	5	75%
3	20	131A	AC53a	20	4	19	5	75%
4	30	124A	AC53a	30	4	29	5	75%
5	10B	171A	AC53b	10A	3.5	12	5	708S
6	10	186A	AC53b	10	3	23	5	697S
7	20	143A	AC53b	20	4	19	5	701S
8	30	134A	AC53b	30	4	29	5	691S

XFE210	Start Class	Maximum Motor FLC	IEC Utilisation Category	Motor Overload Class	Maximum unit current x Motor FLC	Start Time	Starts per Hr	Duty Ratio (AC53a) Bypassed + Off Time (AC53b)
1	10B	370A	AC53a	10A	3.5	12	3	60%
2	10	350A	AC53a	10	3	23	3	60%
3	20	247A	AC53a	20	4	19	3	60%
4	30	248A	AC53a	30	4	29	3	60%
5	10B	390A	AC53b	10A	3.5	12	3	1188S
6	10	364A	AC53b	10	3	23	3	1177S
7	20	288A	AC53b	20	4	19	3	1181S
8	30	256A	AC53b	30	4	29	3	1171S

Setting the XFE Start Class

- ① With 'Starter Disabled' shown on the display, press **ENTER** key once.
- ② With 'Applications' shown on the top line of the display press **↓** key three times until "Advanced" is shown at the top of the display.
- ③ Press **ENTER** once to show "Current" at the top of the display.
- ④ Press **ENTER** once more to show "Rated current" at the top of the display.
- ⑤ Press **↓** key once to display "P106 Start Class" on the top line.
- ⑥ Press **ENTER** once to show "Set Start Class" at the top of the display. Press **↓↑** keys until the required class is shown. Press **ENTER**. Keypad should display "Loading" then "Saved".
- ⑦ At any of the above stages pressing **#** will return the user to the previous menu. The XFE will not start until the control display indicates 'Stopped and ready'.

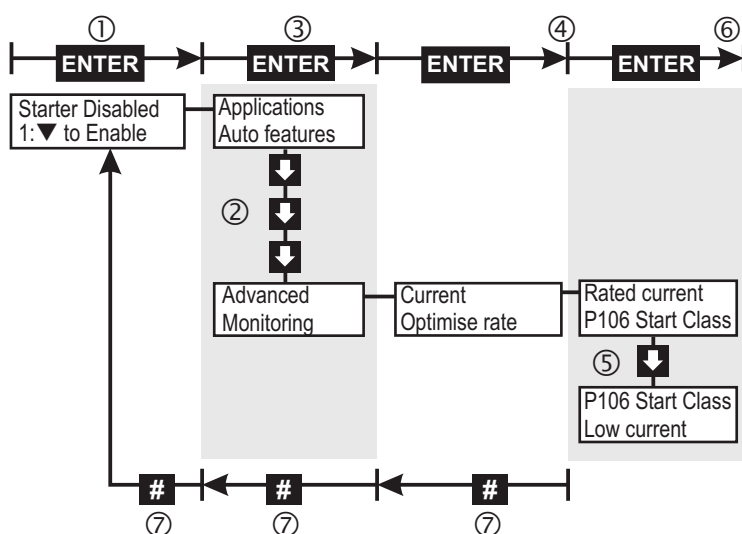

Menu structure

Typical Keypad menu. Contact Fairford for more details.

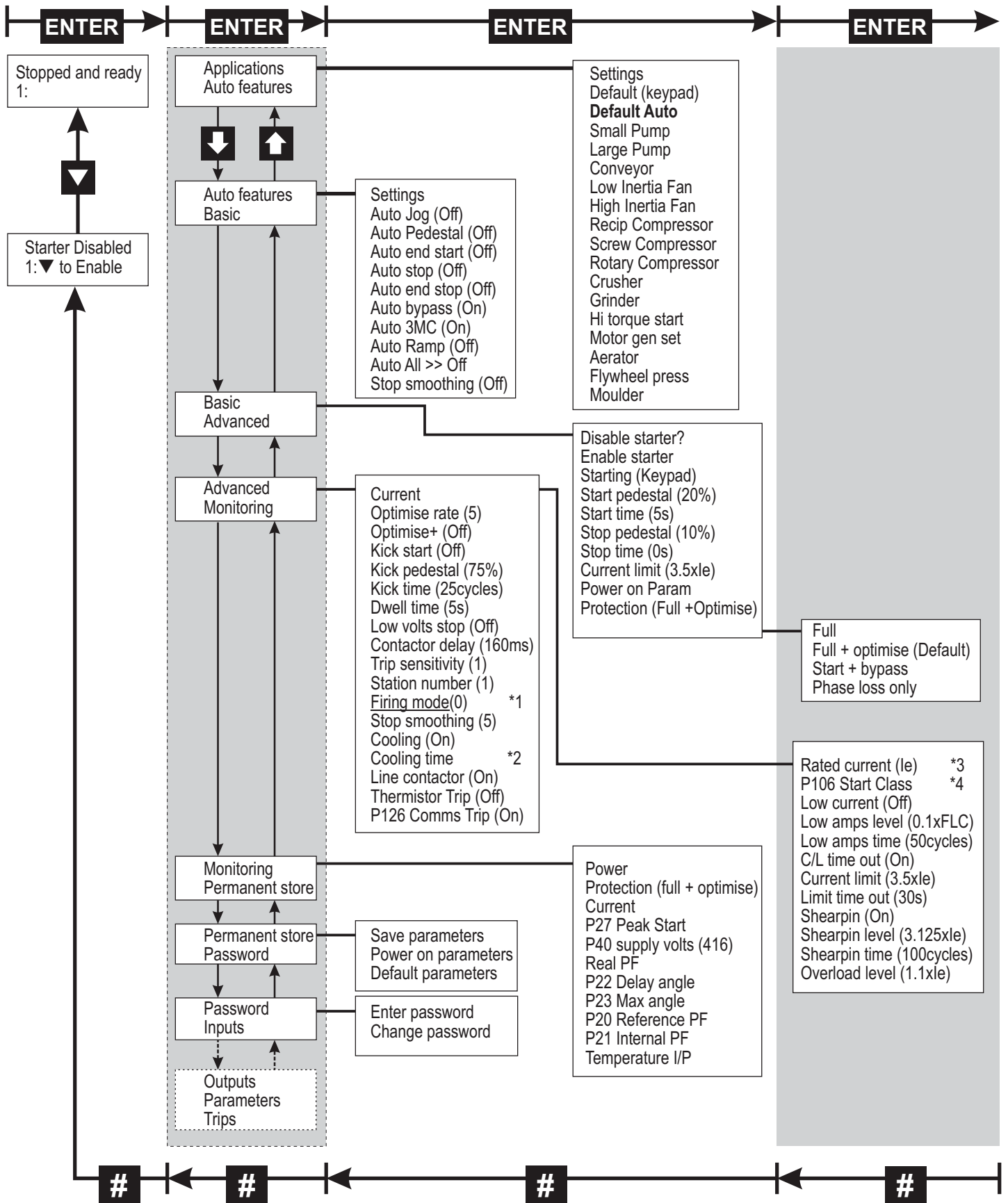

- *1 The "Firing mode" must be set to '1' for the In-Delta configuration.
- *2 The "Cooling time" is dependant on the Model range, Duty rating and Heatsink temperature.
- *3 The "Rated current" setting is for reference only and is not user adjustable.
- *4 "P106 Start Class" is either factory pre-set on set by the user on Initial Start-up.

4 Set-up examples

The XFE should always be **disabled** before making changes. The Soft Starter then remains unable to drive the load until it has been **enabled** via the **Basic Menu**, or the control supply is removed and reapplied, or the ▼ key is pressed when prompted. If the Remote Start/stop is active the XFE cannot be **enabled**.

1 Setting the XFE for large pump application

- ① With 'Starter Disabled' shown on the display, press **ENTER** key once.
- ② With 'Applications' shown on the top line of the display press **ENTER** once.
- ③ With 'Settings' shown at the top of the display press ▼ key three times until 'Large pump' is shown at top of display.
- ④ Press **ENTER** once to select large pump. The display will indicate the parameters changing in short intervals.
- ⑤ With the display top line indicating 'Send to store?', press **ENTER** to save the settings for a large pump to permanent store. Display will flash the message 'Storing' twice to indicate this has been done.
- ⑥ At any of the above stages pressing # will return the user to the previous menu. The XFE will not start until the control display indicates 'Stopped and ready'.

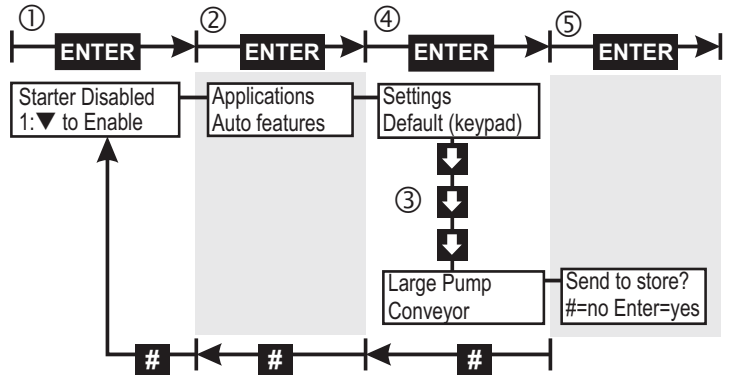

2 Setting the XFE for remote starting and stopping.

- ① With 'Starter Disabled' shown on the display, press **ENTER** key once.
- ② With 'Applications' shown on the top line of the display press ▼ key twice until 'Basic' is shown at the top of the display.
- ③ Press **ENTER** once to select Basic menu.
- ④ Press ▼ key twice until 'Starting' is shown at top of the display then press **ENTER** once to select starting option menu.
- ⑤ With display now indicating 'Starting' on top line press **ENTER** to toggle from 'Keypad Starting' to 'Remote Starting' as shown on bottom line of display.
- ⑥ At any of the above stages pressing # will return the user to the previous menu.

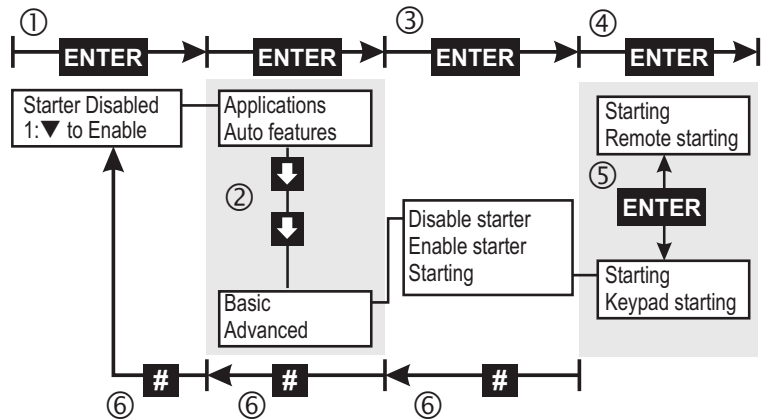

The XFE will now start and stop remotely from the START and STOP switches shown in Figure 2.1, but will return to keypad starting if the control supply on terminals X1 and X2 is removed. Alternatively, to return to keypad starting and stopping, repeat the above procedure and select 'Keypad Starting' at step 5. **To keep the remote start/stop setting after removal of the control supply, the settings must be permanently saved (See 3 below).**

3 Permanently saving parameters set by user.

- ① With 'Starter Disabled' shown on the display, press **ENTER** key once.
- ② With 'Applications' shown on the top line of the display press ▼ key four times until 'Permanent Store' is shown at top of display.
- ③ Press **ENTER** once to select Permanent Store menu.
- ④ With 'Save Param' shown at top of display press **ENTER** once to permanently save parameters. Display will flash twice to indicate this has been done.
- ⑤ At any of the above stages pressing # will return the user to the previous menu.

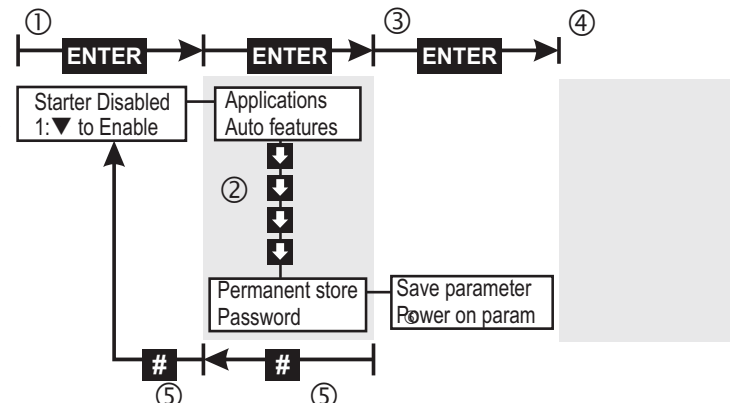

5 Product information

Overcurrent trip curve

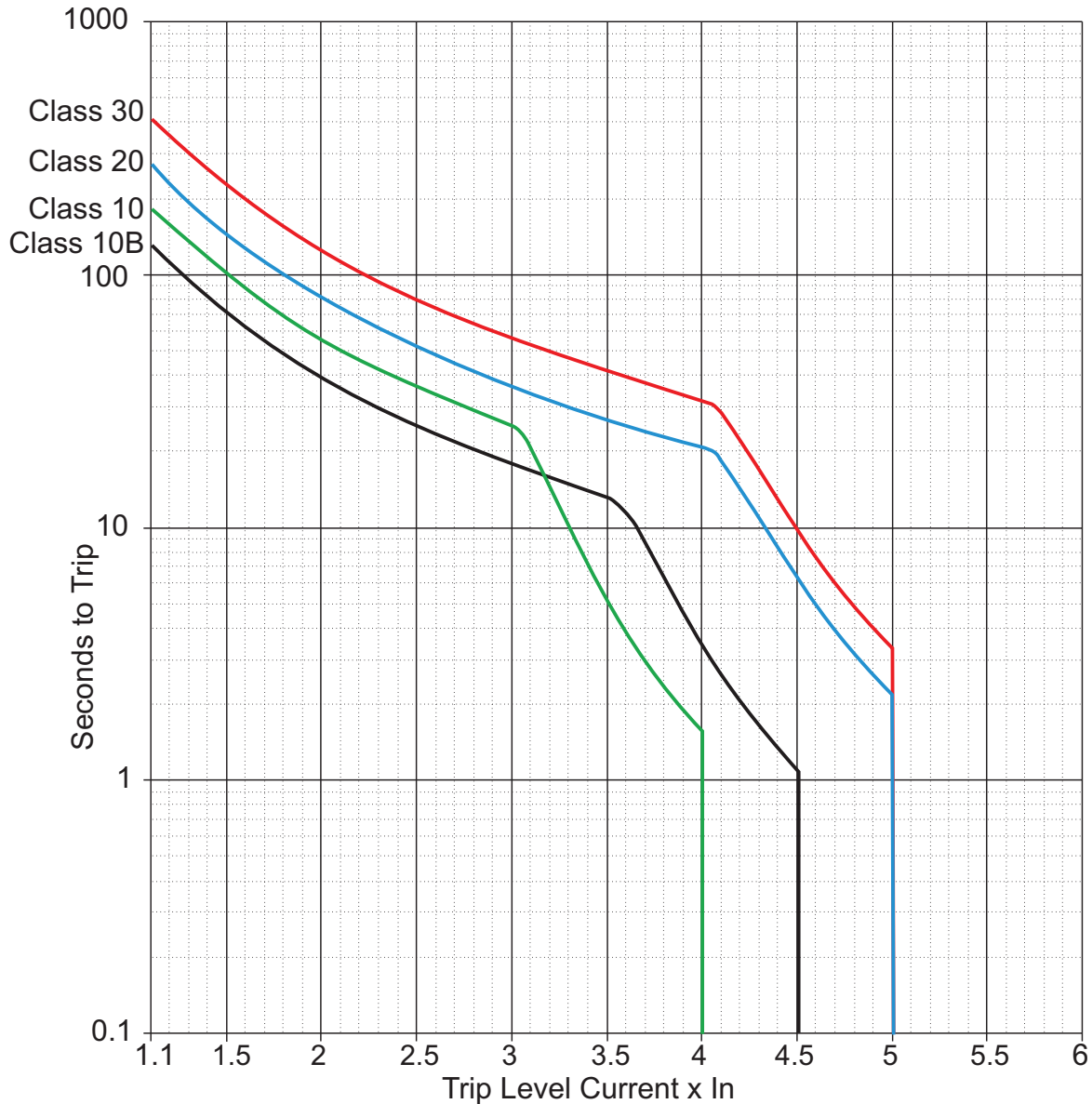

'Current limit' and 'Overload level' settings are adjustable. The XFE monitors current in one phase only and this limits overload currents in accordance with the trip curves shown here (See Menu structure for default settings). Parameter P106 may be changed to select Class 10B, 10, 20 or 30. This will automatically change the motor current rating (Trip level) of the unit to maintain over current protection.

Note: The overload monitors one of the phases only and the 'Current Limit' level is only active during motor starting.

IMPORTANT

It is recommended that the control supply is maintained between starts to ensure the integrity of the overload, which will reset on it's removal.

Cooling

The XFE is designed so that the rated start current/time is close to the maximum allowed. If the start duty is exceeded the unit will trip. All XFE Soft Starts have a forced off cooling time between starts.

In line with the stated IEC starting duties, all XFE 100 series have an enforced off period of 2 minutes, likewise all XFE 200 and XFE 300 series have an enforced off period of 7 minutes set as standard. During this period the display indicates "**Stopped.Cooling**", and the XFE will not respond to a start signal.

AC53a ratings are for Optimising or use without a bypass contactor.

AC53b rating is only for use with a bypass contactor and will trip if one is not used

Trip curves show the nominal times for operation from cold (40°C)

XFE Trip/Fault Codes

Fault Code	Explanation
1 Phase Loss	Input side phase loss at the ramp start, during the ramp or during normal running.
2 Too Hot	The heatsink is above the maximum allowed temperature or i/p open circuit.
3 Comms	There have been a number of serial communication errors but communications are still active.
4 SCR Firing	Short circuit thyristor during normal running.
5 SCR Signal	Short circuit thyristor or Motor side phase loss during the ramp during normal running.
6 SCR Signal	Input side phase loss during normal running. Short circuit thyristor or motor side phase loss during the ramp or during normal running.
7 Sensing Signal	Short circuit thyristor, external noise or motor side phase loss during the ramp or during normal running.
8 Motor, SCR Los	Short circuit thyristor or motor side phase loss at the start of the ramp.
9 Sensing Signal	Short circuit thyristor or external noise during the ramp or during normal running.
10 SCR Shorted	Short circuit thyristor or motor side phase loss during the ramp.
11 Low Current	Current has fallen below the under-current level. Only active during during normal running
12 C/L Time Out	Current limit during the ramp has exceeded the current limit time-out period.
13 Overload	Current has exceeded the overload level . Active at all stages of operation.
14 Shearpin	Current has exceeded the shearpin current level. Only active during normal running
15 Thermistor	Thermistor Input is open circuit or thermistor resistance has exceeded it's trip point.
16 User	A trip input from the user to the soft starter.
17 Comms Timeout	Serial communications have been lost.
18 Bypass failed	Bypass contactor failed to close on AC53b unit.
Stopped. Cooling	Displayed during the period for which the soft starter will not restart to allow heatsink cooling.

Items in **bold** text are user adjustable

Semiconductor Fuse types

XFE No.	Short circuit Amp RMS (kA)	SIBA Fuse	Amps
XFE102	5	2018920.63	63
XFE104	5	2018920.63	63
XFE106	5	2018920.63	63
XFE108	5	2018920.63	63
XFE110	5	2018920.80	80
XFE112	5	2018920.80	80
XFE114	5	2018920.80	80
XFE116	5	2018920.100	100
XFE118	5	2018920.100	100
XFE120	5	2018920.100	100
XFE122	10	2061032.250	250
XFE124	10	2061032.250	250
XFE126	10	2061032.250	250
XFE128	10	2061032.250	250
XFE130	10	2061032.250	250
XFE132	10	2061032.400	400
XFE134	10	2061032.400	400
XFE136	10	2061032.400	400
XFE138	10	2061032.450	450
XFE140	18	2061032.500	500

XFE No.	Short circuit Amp RMS (kA)	SIBA Fuse	Amps
XFE202	18	2061032.630	630
XFE204	18	2061032.630	630
XFE206	18	2063032.630	630
XFE208	18	2063032.800	800
XFE210	18	2063032.800	800
XFE212	30	2063032.900	900
XFE302	30	2068132.800	800
XFE304	30	2067132.1000	1000
XFE306	42	2067132.1000	1000
XFE308	42	2068132.1250	1250
XFE310	42	2068132.1250	1250
XFE312	85	2068132.1400	1400
XFE314	85	2068132.1400	1400
XFE316	85	2068132.1400	1400
XFE318	85	2068132.1400	1400
XFE319	85	2068132.1400	1400
XFE320	85	2 x 2067132.1000	2000
XFE322	85	2 x 2067132.1250	2500
XFE324	100	2 x 2067132.2000	4000
XFE326	100	2 x 2067132.2000	4000

Short circuit co-ordination Type 1

Special purpose fuses, for the protection of semi-conductor devices, rated 700 Vac, can be used to obtain the required short circuit ratings. Suitable for use on a circuit capable of delivering not more than the RMS Symmetrical Amperes indicated in this table at maximum rated operational voltage, when protected by Semiconductor Fuse type, Manufactured by Company and Mod. No. indicated.

These fuses are for short circuit protection of the semiconductors and must be mounted externally by the user **between** the unit and the mains supply, **not between** the unit and the motor.

EMC Emission and Immunity levels

EMC compliance is in accordance with EN 60947-4-2 which refers to the following basic standards:

Note: EN 60947-4-2 is published as a harmonized standard under European Council Directive No.89/336/EEC in relation to the electromagnetic compatibility.

	Basic standard	Level
IMMUNITY Severity level 3	IEC 61000-4-2 IEC 61000-4-6 IEC 61000-4-3 IEC 61000-4-4 IEC 61000-4-5	6kV contact or 8kV air discharge 140dBuV over 0.15-80MHz 10V/m over 80 -1000MHz 2kV/5kHz 2kV line to ground and 1kV line to line
EMISSION Equipment Class A (Industrial)	EN 55011	Class A

Further Information

Document No TF0120 'Guide to Soft Start Drive Product Information', describes the rating index and the meaning of other IEC 60947-4-2 product information in more detail. This is available upon request from Fairford.

Normal service conditions.

Design standards and Approvals

IEC 60947-4-2; EN 60947-4-2 'AC Semiconductor Motor Controllers and Starters'.

Ambient temperature

0°C to 40°C. Above 40°C de-rate linearly by 2% of unit FLC per °C to a maximum of 40% at 60°C.

Transport and Storage

-25°C to +60°C (continuous), -25°C to +75°C (not exceeding 24 hours).

Altitude

Above 1000m de-rate linearly by 1% of unit FLC per 100m to a maximum altitude of 2000m.

Humidity

max. 85% non-condensing, not exceeding 50% at 40°C.

Rated insulation voltage (Ui) 690V

Ingress Protection

IP20 or IP00

Pollution degree 2

Operational Voltage (Ue) 230-460VAC rms, 400-575VAC rms or 500-690VAC rms 3-Phase (-15% +10%)

Rated Frequency

50 - 60Hz +/- 2Hz

Form Designation Form 1

Control Supply Us X1, X2 115V or 230V AC rms (-15% +10%)

Control Supply Uc S0, S1 12V/24V DC or 115/230VAC.

Auxiliary Circuits (programmable relays) Run - 11,12,14, Top of Ramp - 21,22,24. AC1 230VAC 3A

XFE 100 Series terminals		Terminal type	Conductor type	Cable cross section*		Terminal tightening torque
				AWG	mm ²	
Power	L1, L2, L3, T1, T2, T3.	M8 metric threaded studs	Use 75°C copper (CU) conductor only and the wire shall be fitted with close eyelet lug.	1/0	50	106 lb.in. (12 Nm.)
Ground	PE 	M8 metric threaded stud				

XFE 200 Series terminals		Terminal type	Conductor type	Cable cross section*		Busbar size (mm)*	Terminal tightening torque
				AWG	mm ²		
Power	L1, L2, L3, T1, T2, T3.	M8 metric threaded studs	Use 75°C copper (CU) conductor only and the wire shall be fitted with close eyelet lug or use busbar.	2 x 250MCM	2 x 120	20 x 6	106 lb.in. (12 Nm.)
Ground	PE 	M8 metric threaded stud					

XFE 300 Series terminals		Terminal type	Conductor type	Busbar size (mm)*		Terminal tightening torque
Power	L1, L2, L3, T1, T2, T3.	Two off M10 nuts and bolts	Use Busbar	45 x 20	60 x 10 80 x 10	212 lb.in. (24 Nm.)
Ground	PE 	M10 metric threaded stud				

All models - Terminals	Terminal type	Wire type	Cable cross section				Terminal tightening torque
			AWG		mm ²		
			Min.	Max.	Min.	Max.	
X1,X2, S0,S1 11,12,14 21,22,24	Screw clamp terminals	Solid or stranded.	22	14	0.3	2.5	4.4 lb.in. (0.5 Nm.)

To maintain approvals for cable connections, the Wire Terminals should conform to local regulations and be fitted using specified Crimping Tools as indicated by the manufacturer.

* The conductor sizes indicated in the above table are the maximum allowed for each chassis size. The actual conductor used must comply with local wiring regulations.

XFE Current Ratings

XFE No.	Continuous/Optimising				Externally Bypassed			
	-1	-2	-3	-4	-5	-6	-7	-8
	Class10B AC53a 3.5-12:75-5	Class10 AC53a 3-23:75-5	Class20 AC53a 4-19:75-5	Class30 AC53a 4-29:75-5	Class10B AC53b 3.5-12:708	Class10 AC53b 3-23:697	Class20 AC53b 4-19:701	Class30 AC53b 4-29:691
XFE102	3A	3A	3A	3A	5A	4A	3A	3A
XFE104	6A	6A	6A	6A	9A	9A	7A	6A
XFE106	8A	8A	8A	7A	12A	12A	9A	8A
XFE108	13A	13A	10A	9A	18A	19A	12A	11A
XFE110	19A	19A	18A	17A	23A	28A	21A	20A
XFE112	23A	23A	22A	21A	31A	34A	26A	24A
XFE114	27A	27A	25A	24A	35A	40A	30A	29A
XFE116	33A	33A	31A	30A	45A	49A	37A	35A
XFE118	35A	35A	30A	28A	46A	43A	33A	31A
XFE120	41A	44A	35A	33A	47A	51A	39A	37A
XFE122	44A	46A	44A	43A	56A	72A	55A	51A
XFE124	55A	55A	55A	54A	85A	89A	69A	64A
XFE126	70A	70A	59A	58A	85A	84A	63A	61A
XFE128	77A	85A	66A	64A	86A	92A	70A	67A
XFE130	88A	98A	75A	73A	94A	105A	80A	77A
XFE132	98A	108A	83A	81A	107A	117A	89A	85A
XFE134	116A	128A	99A	96A	126A	139A	106A	101A
XFE136	132A	135A	112A	106A	146A	159A	122A	115A
XFE138	154A	166A	131A	124A	171A	186A	143A	134A
XFE140	179A	190A	151A	142A	203A	215A	167A	156A

XFE No.	Continuous/Optimising				Externally Bypassed			
	-1	-2	-3	-4	-5	-6	-7	-8
	Class10B AC53a 3.5-12:60-3	Class10 AC53a 3-23:60-3	Class20 AC53a 4-19:60-3	Class30 AC53a 4-29:60-3	Class10B AC53b 3.5-12:1188	Class10 AC53b 3-23:1177	Class20 AC53b 4-19:1181	Class30 AC53b 4-29:1171
XFE202	209A	225A	174A	164A	218A	232A	178A	167A
XFE204	243A	261A	202A	190A	253A	270A	208A	195A
XFE206	314A	314A	242A	222A	330A	322A	250A	230A
XFE208	350A	320A	258A	235A	360A	344A	272A	242A
XFE210	370A	350A	274A	248A	390A	364A	288A	256A
XFE212	440A	412A	325A	295A	460A	433A	342A	305A
XFE302	500A	500A	445A	420A	520A	515A	460A	430A
XFE304	540A	540A	460A	425A	560A	562A	480A	435A
XFE306	630A	630A	480A	430A	662A	655A	500A	442A
XFE308	780A	750A	600A	530A	817A	780A	628A	543A
XFE310	795A	780A	615A	545A	825A	800A	640A	560A
XFE312	850A	850A	724A	650A	875A	895A	754A	665A
XFE314	950A	950A	810A	727A	1000A	1000A	842A	744A
XFE316	1060A	1060A	904A	812A	1100A	1115A	940A	830A
XFE318	1150A	1150A	980A	880A	1209A	1210A	1020A	900A
XFE319	1150A	1150A	980A	880A	1209A	1210A	1020A	900A
XFE320	1320A	1320A	1050A	930A	1360A	1360A	1080A	950A
XFE322	1400A	1400A	1110A	950A	1400A	1430A	1160A	970A
XFE324	1550A	1520A	1230A	1050A	1560A	1580A	1280A	1075A
XFE326	1850A	1750A	1460A	1190A	1998A	1810A	1520A	1225A

Index Ratings

In line with the stated IEC starting duties, all XFE 100 series have an enforced off period of 2 minutes, likewise all XFE 200 and XFE 300 series have an enforced off period of 7 minutes set as standard. During this period the display indicates "Stopped.Cooling", and the XFE will not respond to a start signal.

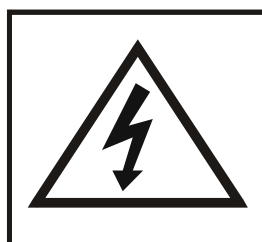

The owner, installer and user is responsible for the correct installation and use of the XFE and must ensure that only qualified personnel install the XFE and that the installation, operation and maintenance of the unit complies with the relevant Codes of Practice, Regulations and Statutory Requirements. The Manufacturer or his agent do not assume any liability, expressed or implied, for any consequence resulting from inappropriate, negligent or incorrect installation, application, use or adjustment of the product or circuit design, or from the mismatch of the unit to a motor. To prevent an electrical shock hazard the XFE must be connected to a safety earth. The unit is not designed for use in hazardous areas. Use in such an area may invalidate the hazardous area certification.